



**m&c ELECTRONICS**

**Die-Casting Worldwide**



# Introduction

- Company name: M&C Electronics Vina Co.,Ltd
- CEO: Mr. Chung Hyun Roh
- Established: October 17<sup>th</sup> 2007
- Capital and Sales
  - Capital : USD7.50 million
  - Sales : USD43million in 2023, USD45million in 2024
- Employees: 800
- Business fields
  - Automotive Motor, ECU, ADAS components
  - Mobile & IT components
  - Game console components
- Factory area: 31,599m<sup>2</sup> (Building area 22,000m<sup>2</sup>)





# Our Achievements

## M&C Electronics



- 2007 ○ - Established – China Corporation
- 2008 ○ - Attained ISO9001 & ISO14001
- 2009 ○ - Official vendor to Samsung Mobile
- 2013 ○ - Established – Vietnam Corporation
- 2014 ○ - Official vendor to Samsung Mobile Vietnam  
- Attained ISO 9001 / ISO 14001
- 2015 ○ - Attained ISO45001 (OHSAS18001)
- 2016 ○ - Attained IATF16949 Certificate  
- Official Automobile Vendor to ZF TRW, SLC & SEM  
- Official vendor to Cpro(CCTV) & KMW(LED)  
- Awarded as one of 'Top 3 companies'  
in Bac Ninh Province
- 2017 ○ - Official Automobile Vendor to LG Innotek  
- Attained Safer Quality (SQ) Certificate  
- Official Vendor to Qualcomm  
- Official Vendor to Hanwha Techwin (CCTV)  
& Ace Antenna (Antenna)
- 2019 ○ - Official Vendor to Jabil (Camera)  
- Attained ISO45001 (OHSAS18001)  
- Attained ISO13485 (Medical device certificate)
- 2020 ○ - Official Vendor to Amazon (Acquired BSCI certificate)  
- Official Vendor to TTI  
- Official Vendor to Mando brose
- 2022 ○ - Official Vendor to Nintendo/Hosiden  
- Official Vendor to HL Klemove

# Location







# I . Core Competencies

# 1. R&D

## Vietnam Factory

### Die-casting Mold design

- 33 Engineers
- CAPA : 12Set / Month

### Machining Jig design

- 28 Engineers

### Automation Equipment

- 10 Engineers

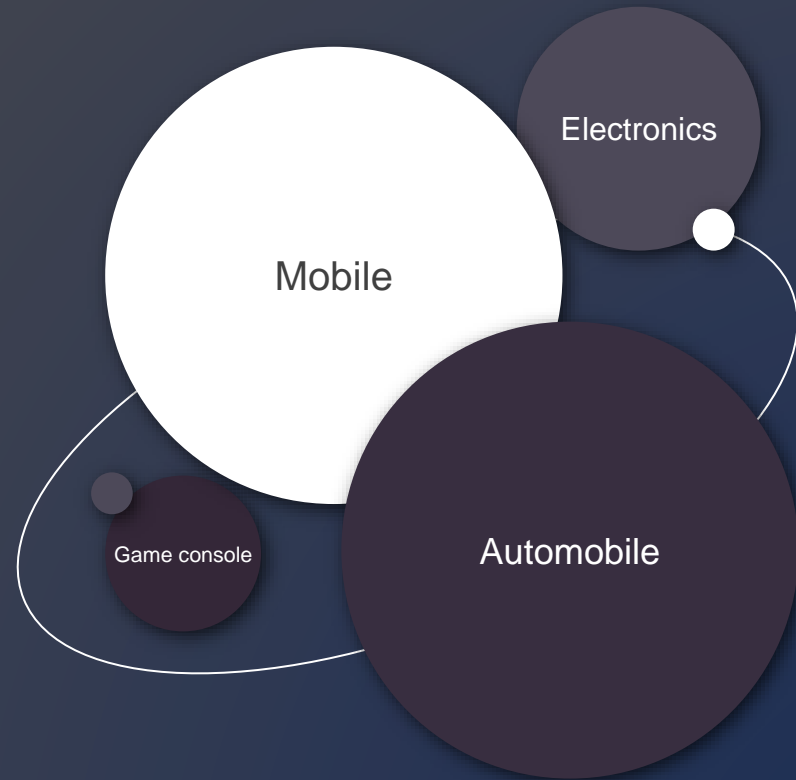

# 2. Manufacturing Line

## ONE-STOP Manufacturing Process

Minimize Outsourcing ▶ Shorter Lead Time ▶ Stronger Quality Control ▶ Competitive Price



1. Tooling



2. Die-casting



3. Press



4. Machining



5. Injection



6. Chromate



7. Painting



8. Packaging





II. Customer &  
Product Portfolio



# 1. Customers

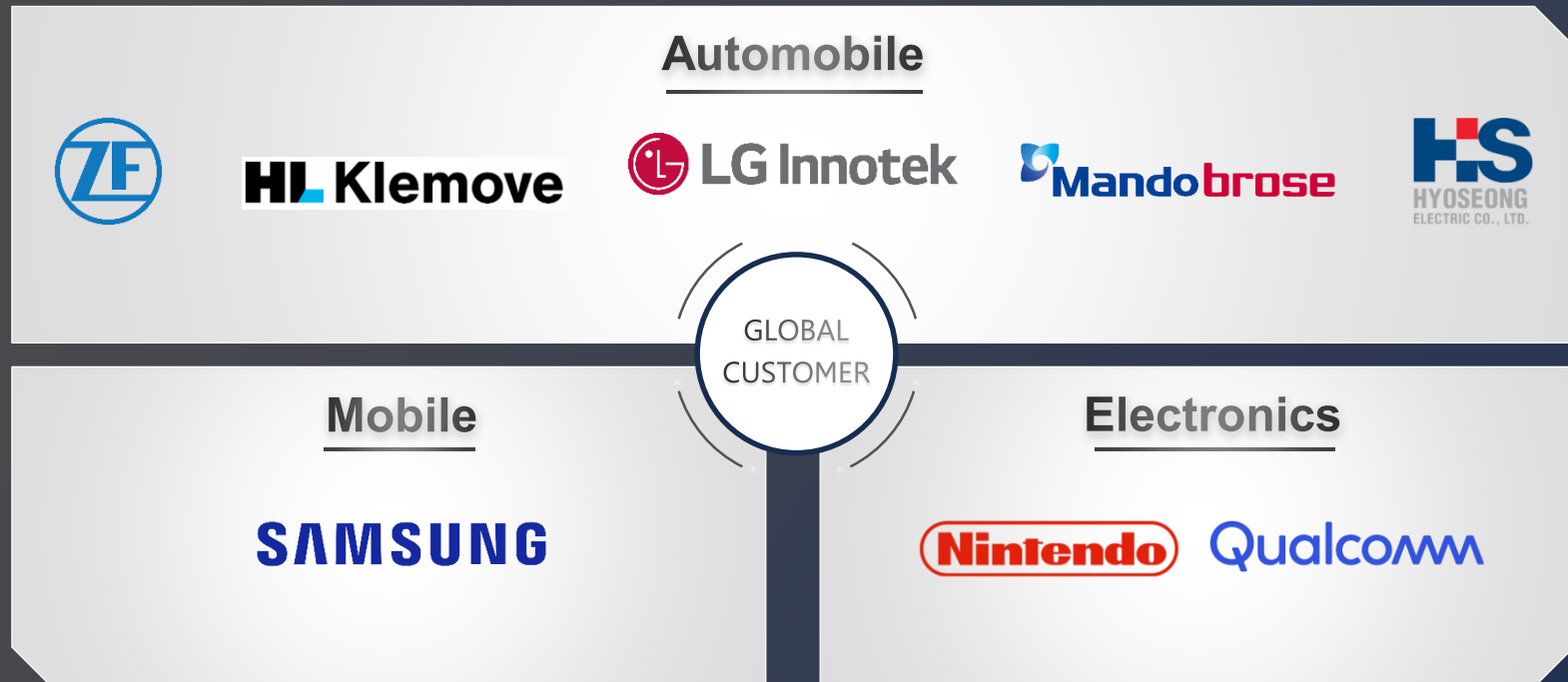

## 2. Product - Automobile



R-EPS Housing & Cover

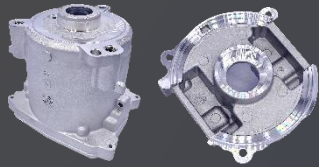

C-EPS Housing & Cover

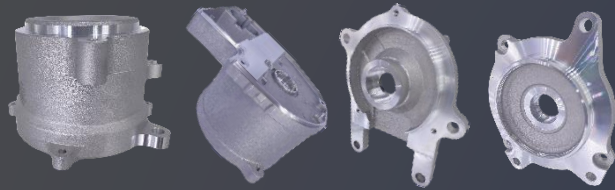

ADAS ECU Housing & Cover

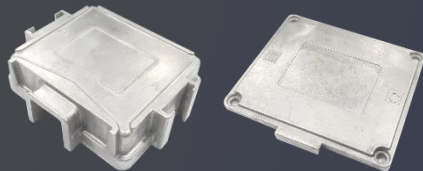

ADAS Camera

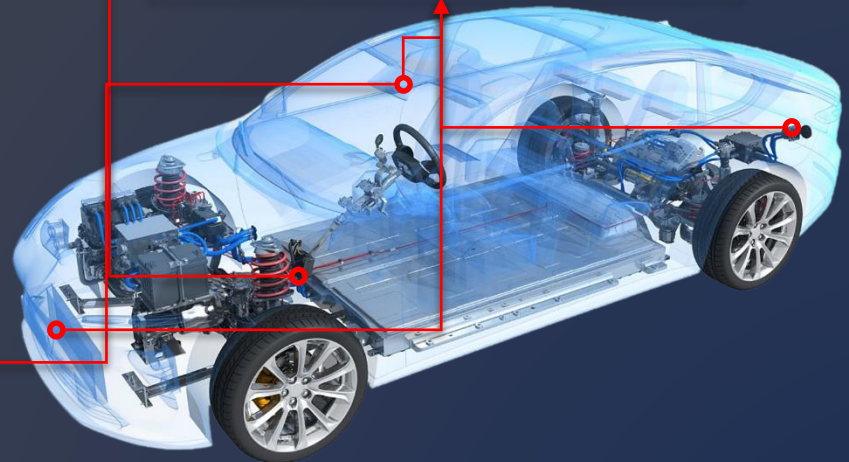
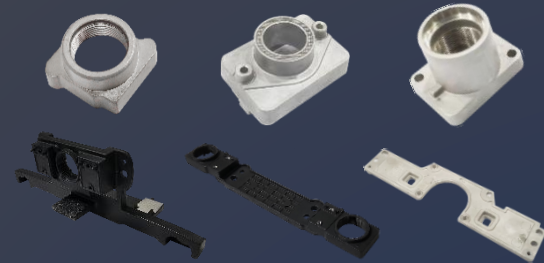



## 2. Product - Automobile



R-EPS Housing & Cover

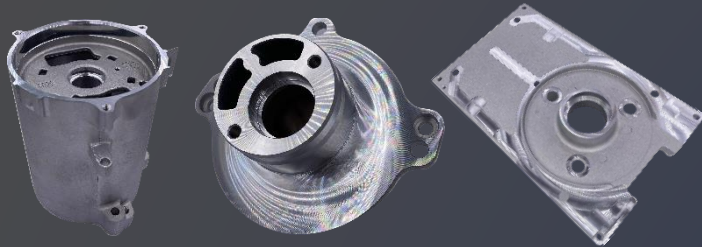

C-EPS Housing & Cover

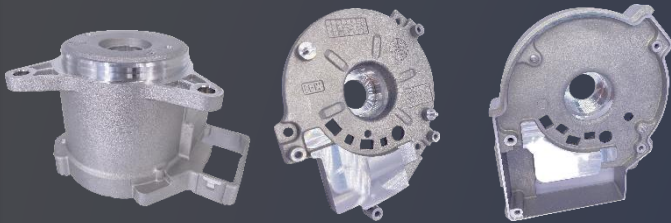

Brake Motor Housing

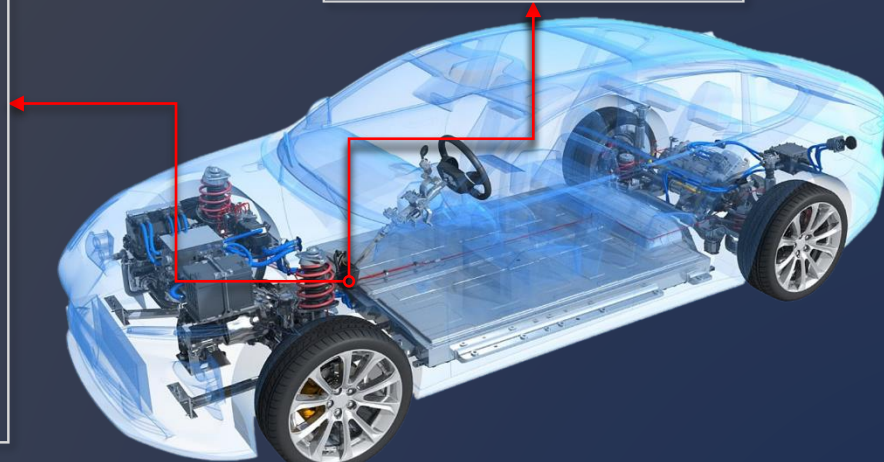

## 2. Product - Automobile

**HL Klemove**

Power Pack Heatsink & MAS Cover

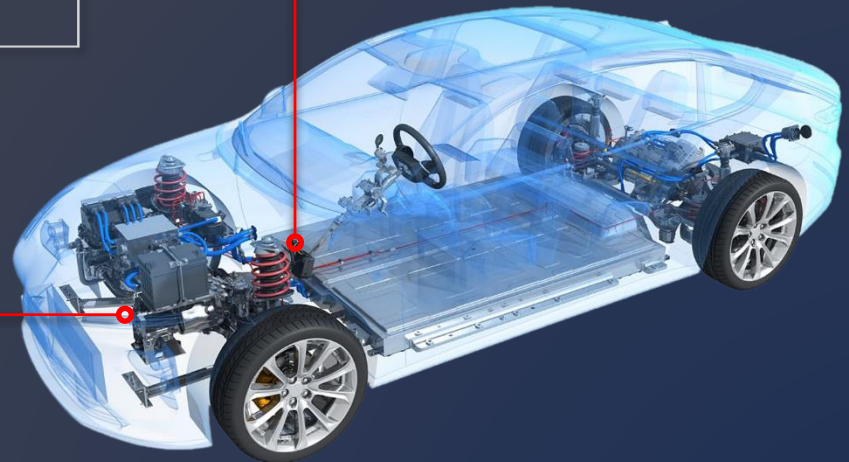
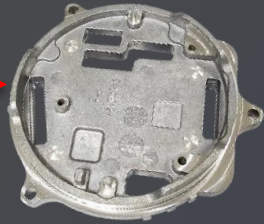

## 2. Product - Automobile



Handle Bar



ADAS Camera Housing & Cover

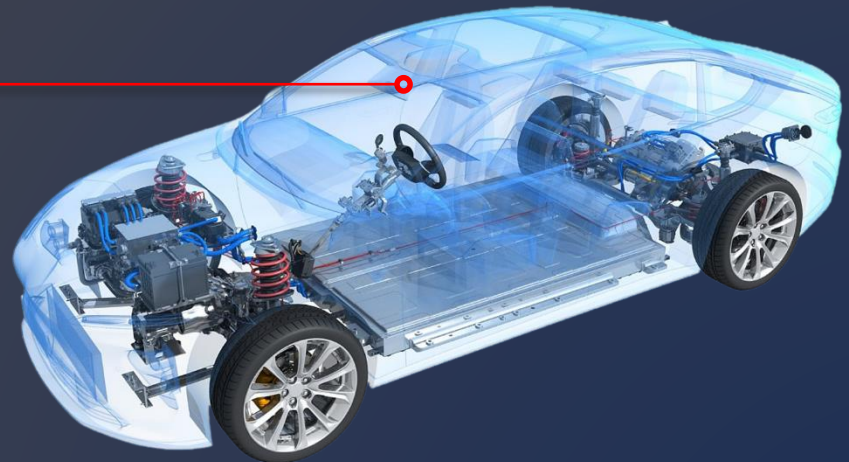
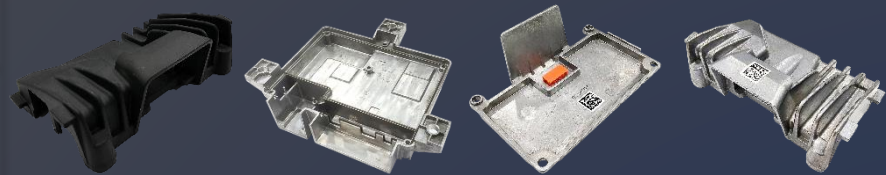



## 2. Product - Automobile



HVAC & ELSD Parts

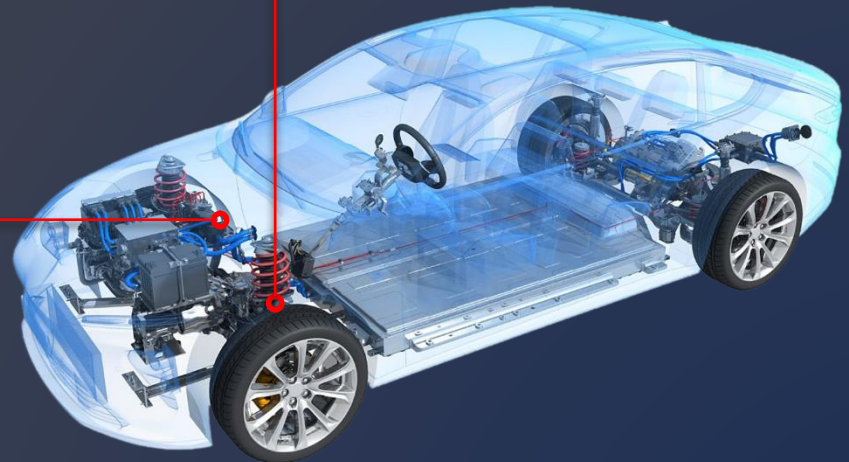
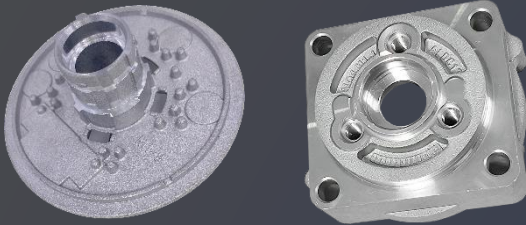

## 2. Product - Mobile

### SAMSUNG

- Die-casting & CNC Machining (2009~Now)

#### Bracket AL

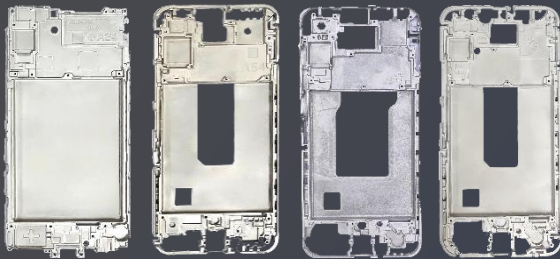

#### AL Block Full CNC

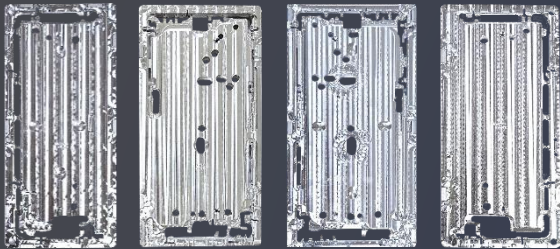

Galaxy A15~A54



Galaxy S24



Galaxy Fold4

## 2. Product - Electronics

### Qualcomm

- World's 1st 5G phone built on M&C's mechanical parts
- Numerous on-going Co-R&D projects with Qualcomm
- Ride platform: Integrated Control System of all ECU's in a car into 1 control center



5G mobile test platform



5G Customer Premises Equipment



Ride 4 & Ride 5

### Nintendo

- Game Console Housing & Cover (Mg)







# III. Manufacturing Capacity

# 1. Manufacturing Machineries

## 1. Mold



- 17 Machines

## 2. Die Casting (MG&AL)



- 28 Machines (MG 8)

## 3. Press



- 41 Machines

## 4. CNC



- 428 Machines

## 5. Injection



- 6 Machines

## 6. Chromate



- 2 Lines

## 7. Painting



- 2 Lines  
Metal Painting & UV Coating

## 8. Assembly



- 2 Lines

## 2. Die-Casting



* Size	No. of Machines	• 12 Engineers
125 Ton	8	• Product size :
350 Ton	17	- up to 200mm X 200mm
400 Ton	3	
* Total	28	



# 3. CNC Machining



Type	No. of Machines	• 22 Engineers
Machining Center	402	• Product size :
Turning Center	20	- up to 500mm X 350mm X 150mm
Tapping	6	
Total	428	



## 4. Chromate



- 5 Engineers
- Automated 2 Lines – Minimizing Human Resources
- Guarantying 72hr Salt spray reliability



# 5. Injection



Type	No. of Machines
90 Ton	1
180 Ton	3
200 Ton	2
Total	6

- 5 Engineers
- Product size :  
- up to 120mm X 70mm / 2Cavity

## 6. Painting



- 3 Engineers
- 500m Automated Line (3 Booth, 6 Spray robots)
- Semi automated UV line & 20 Spray guns (Total 110m line)
- Metal & Plastic painting



# 7. Cleaning



- \* • 1 Engineer
  - Product Size : up to 180mm x 180mm x 30mm
    - Ultrasonic cleansing : 2 General purpose cleansing machines & 1 small size machine
    - 1 High pressure cleansing machine
- \*





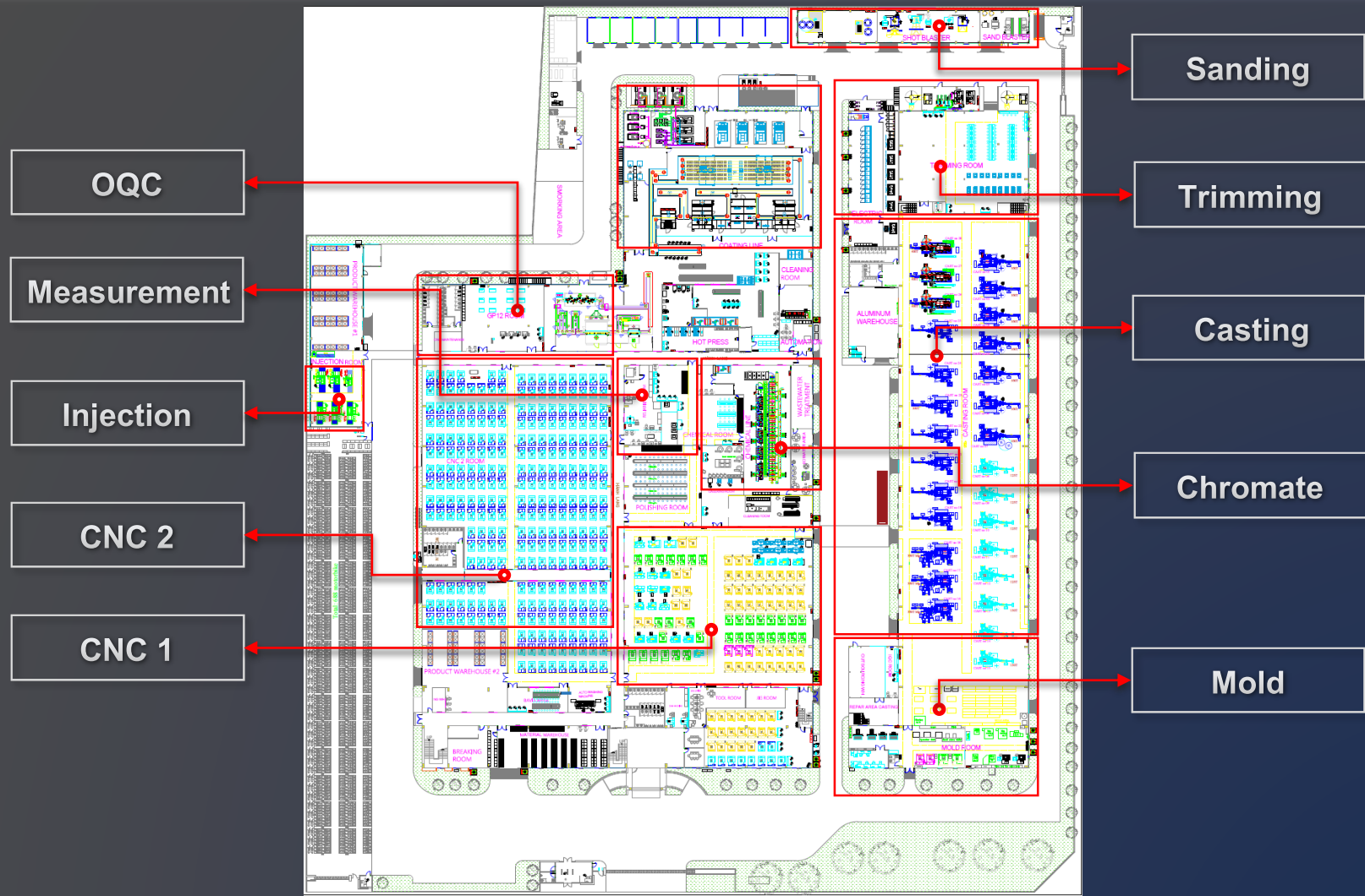







# 8. Layout













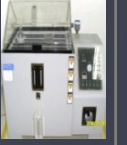



# IV. Quality Assurance

# 1. Validation & Measuring Equipment

Measuring											
	Non-Contact 2D	Contact 3D (CMM)	Adhesive Strength Tester	Surface Roughness Tester	Plastic particle moisture meter	Density meter	Hardness Tester	Pulling Resistance Tester	Hardness Tester	Cleanliness tester	Color meter
Picture of M/C											
# of M/C	4	4	1	1	1	1	1	4	1	1	1
Model	VMC322	HIT 8127C	VML300	SJ500P	MX-50	MD-300S	570 HAD	MK-300	570HAD	BX51M	CM-26dG

Analysis												
	XRF Analyzer	Content Analyzer	Salt spray tester	Thermo-Hygrostat	Thermal Shock	Rubber Friction	UV Rays	Tensile Machine	Drop Tester	Hardness Tester	Extraction Machine	X-Ray
Picture of M/C												
# of M/C	1	2	2	1	1	1	1	2	1	1	1	1
Model	EDX-GP	Spectro Max	HL-60SS	KJU-150L	TST-70A	MST-803B	TST-70A	HZ-1004C	MST420	YK-5022	CRM 650	OSPREY 160-5

# 2. Quality Certifications



ISO 9001



ISO 14001



IATF 16949

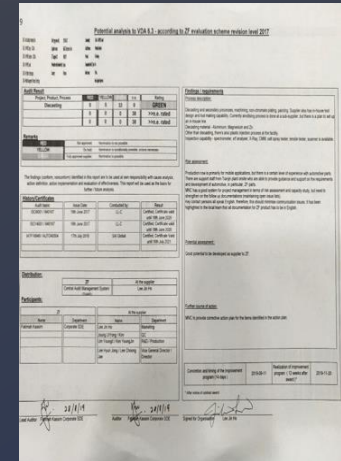

VDA 6.3



ISO 45001



ISO 13485



ISO 22716

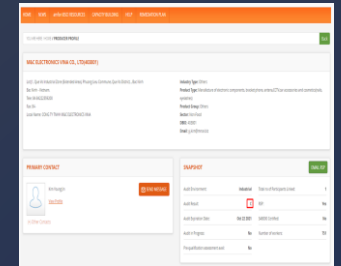

BSCI





# Thank you

Company makes you the best, You make Company the best

회사는 당신을 최고로, 당신은 회사를 최고로

公司因你而成功, 你因公司而伟大

